

Panel

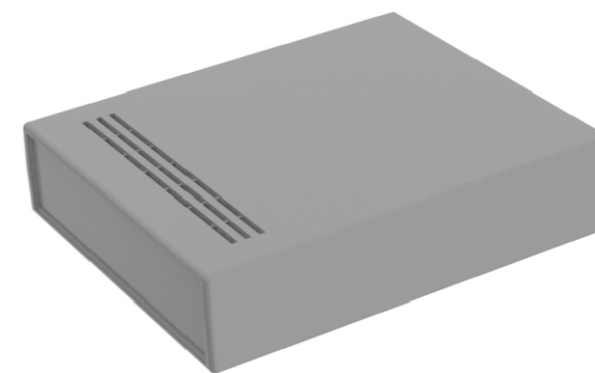
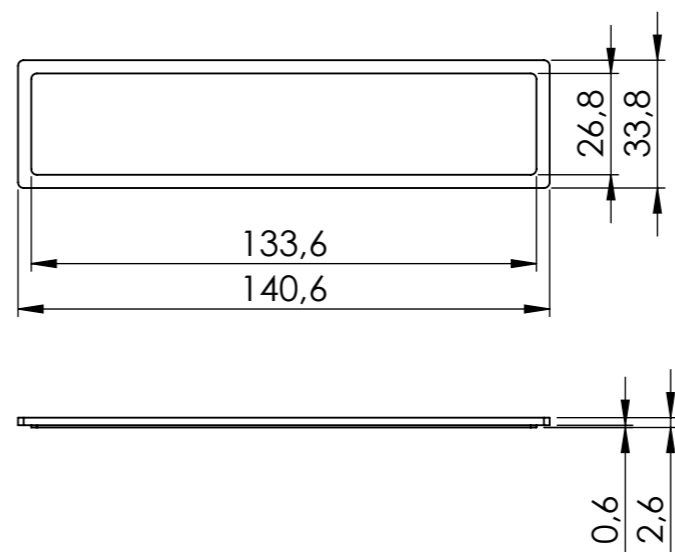

- Elementy składowe:
- obudowa góra
 - obudowa dół
 - 2 panele
 - 4 wkręty
 - 4 nóżki

Tolerancja wymiarowa: $\pm 0,5$ mm

Format	Skala
A3	1:2
Nr Produktu	
KM - 190W	



MASZCZYK®

OBUDOWY DLA ELEKTRONIKI

„MASZCZYK”
05-071 Sulejówek-Miłosna
ul. Mickiewicza 10
tel: (22) 783-45-20 kom: 602-726-086